



12-38-0000

VHF / UHF Transceiver



# PRODUCT MANUAL

Version 1.05

March 2020

## Salcom Product Documentation

This document is designed to familiarize you with Salcom products and guide you through the hardware, configuration, installation and overall system management.

Salcom is an environmentally conscious company and in an effort to conserve paper no longer prints manuals with shipped products. All relevant documentation can be downloaded in PDF form from our website [www.salcom.com](http://www.salcom.com)

## Warranty and Disclaimer

Salcom products are warranted for a period of 12 months from the date of purchase against faulty materials and workmanship. Should any fault occur the unit should be returned to the vendor, freight pre-paid. Please include a description of the fault to assist with prompt return. Any unauthorised alterations or repairs will invalidate the warranty.

All information provided in this document is carefully prepared and offered in good faith as a guide in the installation, use and servicing of Salcom products. Installers must ensure that the final installation operates satisfactorily within the relevant regulatory requirements. Salcom accept no responsibility for incorrect installation. We reserve the right to change products, specifications and installation data at any time without notice

## Product Overview

The 12-38-0000 transceiver is capable of accurate control and telemetry over long distances. Designed to be used in industrial environments it can withstand temperature extremes as well as being resilient to electrical noise often found in industrial plants.

The transceiver, along with its integrated input/output interface is designed for the control and telemetry of industrial machines with high accuracy and speed.

The 12-38-0000 has an on-board SD card which is used to store the configuration of a unit, this allows for ease of copying a configuration between units e.g. to replicate a system, the capturing of log files and storage of audio wave files. The unit can be set up to respond to an event, such as an input, by selecting a radio channel and broadcasting the audio wave file. Anyone carrying a radio transceiver, set to that channel, can then receive the message.

The 12-38-0000 could also be configured as a store and forward radio repeater to extend the radio range of any installation. This will allow monitoring and control of sites in difficult locations without clear radio access.

The 12-38-0000 is a 5-watt analogue transceiver with POCSAG capability for both transmitting and receiving and comes in two variants, a VHF (136-174 MHz) or UHF (440-470 MHz). All parameters are programmable such as frequency, power output, deviation, POCSAG data transmission.

The USB port, or the RS232 serial port can be used to initiate paging transmissions using the SALCOM propriety protocol, Paging Entry Protocol (PET) or Telocator Alphanumeric Protocol (TAP) PG1 protocol

## Installation and Connections

The power supply is connected via P1, green power connector to +13.8 Volts DC and Ground. The 12-38 is protected against reversed supply connections. The power source must be reasonably noise free.

Radiation Hazard: Important! To comply with FCC Controlled/Occupational Exposure Limits the aerial must be positioned or mounted to operate at least 0.26 metres away from Operational Staff and 0.57 metres away from the general public.

It is recommended to site the aerial a few metres away from the 12-38 to avoid the possibility of RF feedback causing problems with the transmitter operation. An outside aerial is preferable and will provide better radio coverage. The aerial connection is via the BNC connector and should present a nominal load of  $50\Omega$ , with a VSWR of better than 1.8:1.

External indicators consist of a power indicator GREEN LED, normally flashing ON once a second to indicate healthy microcontroller operation.

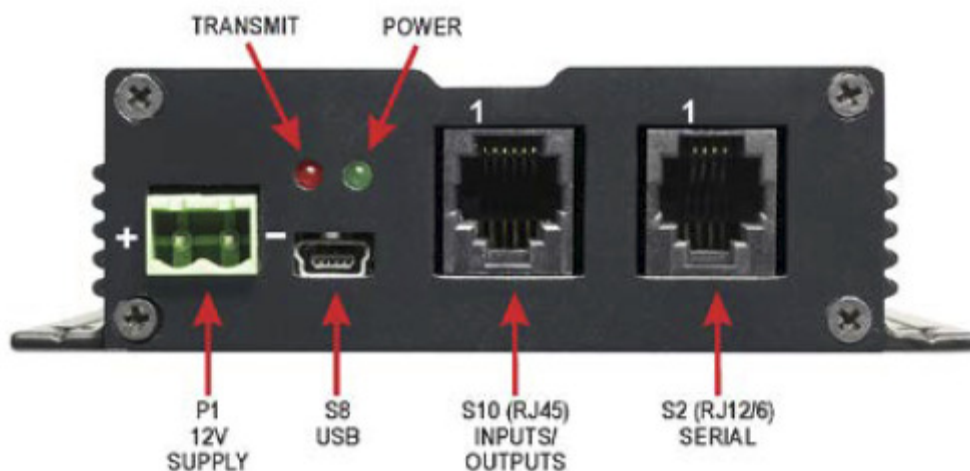

S2 RJ12	
Pin	Description
1	Ground
2	Output 1
3	Input 2
4	Input 1
5	RS232 Tx
6	RS232 Rx

S10 RJ45	
Pin	Description
1	Ground
2	PTT Input
3	Mic / AV In
4	Input 3
5	Output 2
6	Busy
7	Speaker / AV Out
8	+5V

Output1 and 2 are Open Collector and Inputs 1, 2 and 3 are triggered by grounding the pins.

## Configuration

All serial commands are sent and received using a standard terminal application connected at 9600:N:8:1 using a 12-45 programming adaptor. Ensure that the correct COM port is selected.

Sending MAP<CR> to the 12-38 will display current configuration information. To change a parameter refer to the terminal programme instructions. An example is given below:

**+03=456675000<CR>**      to change the RX frequency

### Using the USB

If the connection is via the USB then the 12-38 will appear as a drive on the computer. The configuration information is held in the config.ini file which can be opened and edited using a standard text editor. Once the required parameter has been changed save the file back to the original location.

Whilst the USB is connected the Green LED will flash faster.

### Parameter Format

Each parameter follows the same format. An example is given below:

<b><i>;Tx Frequency set the Transit Frequency in Hz</i></b>	the command description
<b><i>;<b>+20=456675000</b></i></b>	an example for the correct format
<b><i><b>+20=456675000</b></i></b>	the actual parameter set

## Analogue Transmissions Via External Modulation Source

Connect the External Modulation Source to Pin 3 of connector S10. This input is configured for a fixed amplitude input source of 100mV rms , or 280mV p-p. Monitor the RF output on a FM modulation on a meter and adjust the deviation to  $\pm 4$ kHz. Adjust the deviation by fine adjustment of the input signal, or via the PSD by changing the DAC setting within the '**Audio in Atten**' box. Do not click '**Enable Calibration**' tick box for this adjustment. It is important to '**Read**' first, then alter the settings, a higher number gives more deviation and lower number less deviation.

It is also important to keep the deviation to  $\pm 4$ kHz to avoid getting into the compression range. Then press '**Program**' in the '**Configuration**' section to save the settings.

## Salcom Protocol

Salcom protocol takes the basic form: **PPXXXXXXXXsLsMMMMMM<CR>**, where:

- P** is either **CA** (512 baud alpha), **CN** (512 baud numeric), **ca** (1200 baud alpha), or **cn** (1200 baud numeric).
- X** is a 7 digit RIC code.
- S** is a space.
- L** is a digit (1 to 4 beep level)
- M** is the message payload (up to 240 characters).
- <CR>** is a carriage return (enter key)

### CA \_\_\_\_\_

Usage: CA<pager#>[<space>]<level>[<space>]<message><CR>

Description: Call alphanumeric pager

Example: CA1119358 1 Please return to reception<CR>

Response: CA11193581<CR><SPACE>Page Sent<CR><LF>

### CN \_\_\_\_\_

Usage: CN<pager#>[<space>]<level>[<space>]<message><CR>

Description: Call numeric pager

Example: CN1119358 1 777<CR>

Response: CN11193581<CR><SPACE>Page Sent<CR><LF>

### RES \_\_\_\_\_

Usage: RES<CR>

Description: Reset 12-38 microcontroller

Example: RES<CR>

Response: SALCOM 12-38-0000 VX.XX<CR><LF>



SN? \_\_\_\_\_

Usage: SN?<CR>

Description: Retrieve unit serial number and firmware revision

Example: SN?<CR>

Response: SALCOM 12-38-0000 VX.XX 5122345<CR><LF>

## Trouble Shooting

The following table may help in problem solving where necessary.

Fault	Check
No illumination of Green LED	Bad power supply connection
Input activated but no transmission	Software configuration incorrect
Unit transmits but nothing received	Poor aerial Wrong frequency Incorrect RIC Incorrect baud-rate Power too low Unit too hot (the unit will also send out an alter via the serial port) Too much vibration
No RS232 serial communication	Incorrect COM port connection selected Software configuration incorrect Cable faulty
Unit starts, but does not complete transmission	Poor supply voltage RF interference (the unit will also report an error on the terminal port)

## Technical Specification

<b>Technical Specification</b> <b>12-38-0000 – VHF / UHF Transceiver</b>		
Frequency Range	136 - 174MHz - VHF (Model No. 12-38-0150) 440 - 470MHz - UHF (Model No. 12-38-0450)	
Frequency Selection	User configurable	
Power Supply	+13.8V typical (11 to 15 VDC range)	
Power Consumption	Standby: 140mA Transmit: 1.2A @ 5W	
Transmit Power	5W, 4W, 2W, 1W, 500mW, 250mW	
Channel Spacing	6.25kHz, 12.5kHz, 25kHz	
Modulation	FSK with NRZ Data True FM for Audio	
Deviation	±2.25kHz or ±4.5kHz	
Transmit Duty Cycle	Up to 100%	
Receiver Sensitivity	-119dBm for 12 dB SINAD	
Audio Modes	Analogue FM transmission and reception	
Audio Conditioning	300Hz to 3kHz passband software defined pre-emphasis DTMF and CTCSS (<300Hz)	
Muting	Software defined muting level	
Baud Rates	512, 1200	
Message Format	POCSAG	
Configuration Application	Salcom Configuration Tool	
Programming Cable	12-45-0000 (RJ12 to DB9) Can be used with a USB to RS232 DB9 Serial Adapter Cable	
Serial Port	9600 , N, 8, 1; RS232	
Serial Protocols	Salcom	
Discrete Inputs	3 (Ground activated)	
Discrete Outputs	2 (Open collector)	
Other I/O	PTT; Busy; Mic/AV In; Mic/AV Out; +5V	
Connectors	Serial Port (RS232) = RJ12 (6P6C) Serial Port / Flash Drive = mini USB Input / Outputs = RJ45 (8C)	
Power Connector	2-way plug & socket, screw connections (supplied)	
RF Connector	50Ω BNC	
Environmental Protection	Not suitable for outdoor use and should be protected from adverse environmental conditions	
Operating Temperature	-10°C to +60°C (+14°F to +140°F)	
Indicators	Power LED (Green) - Slow Flashing = Normal Operation - Rapid Flashing = USB Connected Status LED (Red) - On = Transmitting - Flashing = Error Condition	
Weight	318g	
Enclosure Dimensions	100mm x 130mm x 30mm (WxDxH)	

[12-38-0000 VHF AND UHF TRANSCEIVER](#)
[Product Manual](#)

Enclosure Material	Extruded aluminium
Colour	Matt black
Type Approvals	AS/NZS 4295: 2004 (RF) AS/NZS 4769.1:2000 + Amendment 1:2002 (RF)

## How to Contact Us

Sea Air and Land Communications (Salcom) Ltd  
10 Vanadium Place  
Addington  
Christchurch 8024  
New Zealand  
T: +64 (0)3 379 2298  
W: [www.salcom.com](http://www.salcom.com)  
E: [sales@salcom.com](mailto:sales@salcom.com)

Salcom is pleased to confirm that it is a New Zealand FernMark Licensee. The FernMark Licence Programme is the Government's official 'country of origin' accreditation programme, designed to protect and promote New Zealand products to the world.

- From now on, you should see the 'FernMark' (the Government's trademarked Silver Fern) appear on some or all of our products. The FernMark acts as a 'tick of approval' from the New Zealand Government.
- This 'tick of approval' means we've met all the New Zealand Government's eligibility criteria, which should give you huge amounts of confidence in what you're buying.
- The Programme employs a global monitoring service, Yellow Brand Protection, that trawls the web for illegitimate use of the FernMark. This means that when you see the FernMark on a product, you know it's an authentic New Zealand product.

